



The ATM Forum
Technical Committee

ATM Physical Medium
Dependent Interface
Specification for 155 Mb/s
over Twisted Pair Cable

af-phy-0015.000

The ATM Forum Technical Committee ATM Physical Medium Dependent Interface Specification for 155 Mb/s over Twisted Pair Cable

ATM Physical Medium Dependent Interface Specification for 155 Mb/s over Twisted Pair Cable

Version 1.0

September, 1994

(C) 1994 The ATM Forum. All Rights Reserved. No part of this publication may be reproduced in any form or by any means.

The information in this publication is believed to be accurate as of its publication date. Such information is subject to change without notice and the ATM Forum is not responsible for any errors. The ATM Forum does not assume any responsibility to update or correct any information in this publication. Notwithstanding anything to the contrary, neither The ATM Forum nor the publisher make any representation or warranty, expressed or implied, concerning the completeness, accuracy, or applicability of any information contained in this publication. No liability of any kind shall be assumed by The ATM Forum or the publisher as a result of reliance upon any information contained in this publication.

The receipt or any use of this document or its contents does not in any way create by implication or otherwise:

- Any express or implied license or right to or under any ATM Forum member company's patent, copyright, trademark or trade secret rights which are or may be associated with the ideas, techniques, concepts or expressions contained herein; nor
- Any warranty or representation that any ATM Forum member companies will announce any product(s) and/or service(s) related thereto, or if such announcements are made, that such announced product(s) and/or service(s) embody any or all of the ideas, technologies, or concepts contained herein; nor
- Any form of relationship between any ATM Forum member companies and the recipient or user of this document.

Implementation or use of specific ATM recommendations and/or specifications or recommendations of the ATM Forum or any committee of the ATM Forum will be voluntary, and no company shall agree or be obliged to implement them by virtue of participation in the ATM Forum.

The ATM Forum is a non-profit international organization accelerating industry cooperation on ATM technology. The ATM Forum does not, expressly or otherwise, endorse or promote any specific products or services.

The ATM Forum Technical Committee ATM Physical Medium Dependent Interface Specification for 155 Mb/s over Twisted Pair Cable

Preface

Since the publication of The ATM Forum ATM User-Network Interface Specification, Version 3.0 (UNI 3.0), the ATM Forum Technical Committee has completed the specification of additional physical layer interface agreements. These additional interfaces are:

- ATM Physical Medium Dependent Interface Specification for 155 Mb/s over Twisted Pair Cable
- Mid-range Physical Layer Specification for Category 3 Unshielded Twisted Pair
- DS1 Physical Layer Specification

This document contains the ATM Physical Medium Dependent Interface Specification for 155 Mb/s over Twisted Pair Cable.

Acknowledgment

The assistance of Bill Stephens who provided source material for this document is appreciated. Without his efforts this document could not have been assembled.

The material submitted is based upon documents that have been edited at various times by Daun Langston, Ken Brinkerhoff, Moshe DeLeon, Stanley Ooi, and David Foote. Their assistance as well as all the members of The ATM Forum who have brought contributions towards, discussed and reviewed the enclosed information is appreciated.

Greg Ratta, Chief Editor

The ATM Forum Technical Committee ATM Physical Medium Dependent Interface Specification for 155 Mb/s over Twisted Pair Cable

1. Introduction

This specification describes the Physical Medium Dependent (PMD) sublayer for a 155.52 Mb/s private User Network Interface (UNI) over twisted pair cabling. The remaining Physical layer functions as required by a Transmission Convergence (TC) sublayer are referenced in this specification to existing or in-progress documents from ANSI, ITU-T, or the ATM Forum.

1.1. Scope

The PMD provides the digital baseband point-to-point communication between ATM user devices and ATM network equipment. The PMD shall provide all the services required to transport a suitably coded digital bit stream across the link segment. This PMD sublayer specification assumes an accompanying 155.52 Mb/s SONET/SDH based ATM TC sublayer. Operation of other TCs with this PMD is beyond the scope of this specification.

The PMD sublayer specified in this document has the following general characteristics:

- Provides a means of coupling the SONET/SDH TC physical sublayer to the twisted pair line segment by way of the Active Interface.
- Provides for driving twisted pair cable between two active electrical interfaces.
- Supports the topology and distance requirements of the building and wiring standards, specifically as described in EIA/TIA-568-A^[1] and ISO/IEC DIS 11801^[2].

1.2. Transmission Convergence Sublayer Specification

The Transmission Convergence (TC) sublayer deals with Physical Layer aspects which are independent of the transmission medium characteristics. Most of the functions comprising the TC sublayer are involved with the generating and processing of overhead bytes contained in the SONET/SDH frame. Unless otherwise described in this specification, the requirements for the TC functions are as defined for the private UNI in the ATM Forum Technical Committee ATM UNI Specification, Version 3.1, Section 2.1^[3].

Transmission Convergence Sublayer	HEC Generation/Verification Cell Scrambling/Descrambling Cell Delineation (HEC) Path Signal Identification (C2) Frequency Justification/Pointer Processing SONET Scrambling/Descrambling Transmission Frame Generation/Recovery
Physical Media Dependent Sublayer	Bit Timing, Line Coding Physical Medium

Figure 1-1 Physical Layer Functions (U-plane)

1.3. Acronym Glossary

AII	Active Input Interface
AOI	Active Output Interface
ATM	Asynchronous Transfer Mode
BER	Bit Error Rate
EMC	Electromagnetic Compatibility
ITU-T	International Telecommunication Union - Telecommunication Standardization Sector
MIC	Media Interface Connector
NEXT	Near End Crosstalk
NRZ	Non-Return to Zero
PC	Printed Circuit
PMD	Physical Medium Dependent
SDH	Synchronous Digital Hierarchy
SONET	Synchronous Optical NETWORK
SRL	Structural Return Loss
STS	Synchronous Transfer Signal
STM	Synchronous Transfer Mode
STP	Shielded Twisted Pair
TC	Transmission Convergence
UNI	User Network Interface
UTP	Unshielded Twisted Pair

2. Transmission Requirements

2.1. Line Rates and Bit Timing

(R) The bit stream of this PMD interface has an external frame based upon the SONET STS-3c frame as defined in ATM Forum UNI Specification 3.1, Section 2.1^[3].

(R) The encoded line rate shall be 155.52 Mbaud +/- 20 ppm for ATM network equipment.

(R) The transmitter at the ATM user device uses a transmit clock which is derived from its received line signal.

(R) In the absence of a valid clock derived from the received line signal, the transmitter at the ATM user device shall use a free-running transmit clock that operates at 155.52 MHz +/- 100 ppm.

2.2. Line Code

(R) The line coding shall be binary Non-Return to Zero (NRZ).

2.3. Bit Error Rate

(R) The Active Input Interface shall operate with a bit error rate not to exceed 10^{-10} when provided with a signal transmitted through the channel reference model described in Section 5 with the worst-case crosstalk noise characteristics as specified in Section 5.

3. Active Output Interface (AOI)

(R) The PMD sublayer shall provide transmit functions in accordance with the electrical specifications of this Section.

The transmitter transforms the bit stream that is presented from the TC sublayer to the equivalent differential voltage signal to be placed onto the media. The active output interface is defined to operate with two cable types as defined in Section 5; 100 ohm category 5 Unshielded Twisted Pair (UTP), and 150 ohm Shielded Twisted Pair (STP).

(R) A logical ONE from the TC shall be represented by a positive voltage on the TX+ pin with respect to the TX- pin. A logical ZERO shall be represented by a positive voltage on the TX- pin with respect to the TX+ pin.

3.1. Test Load

(R) Unless otherwise specified, all measurements in this Section shall utilize the reference test load.

3.1.1. UTP Test Load

(R) The test load shall consist of a single 100 ohm +/- 0.2% resistor connected across the transmit pins of the AOI. For frequencies < 100 MHz, the series inductance of the resistor shall be less than 20 nH and the parallel capacitance shall be less than 2 pF.

3.1.2. STP Test Load

(R) The test load shall consist of a single 150 ohm +/- 0.2% resistor connected across the transmit pins of the AOI. For frequencies < 100 MHz, the series inductance of the resistor shall be less than 30 nH and the parallel capacitance shall be less than 1.5 pF.

3.2. Differential Output Voltage

(R) When TX+ and TX- are terminated in the test loads of Section 3.1, the peak-to-peak differential output voltage between TX+ and TX- shall be:

$$940 \text{ mV} < V_{out} < 1060 \text{ mV} \quad \text{'for UTP test load'}$$

$$1150 \text{ mV} < V_{out} < 1300 \text{ mV} \quad \text{'for STP test load'}$$

3.3. Waveform Overshoot

Overshoot is defined as the percentage excursion of the differential signal transition beyond its final adjusted value (Vout) during the symbol interval following the preceding 50% voltage crossing.

(R) The overshoot shall be less than 10%.

(R) Any overshoot shall settle to its final adjusted value within 3.2 ns from the beginning of the preceding 50% voltage crossing.

3.4. Return Loss

(R) The UTP and STP Active Output Interfaces (AOI) shall be implemented such that the following return loss characteristics are satisfied for the specified reference impedance (UTP - 100 ohms +/- 15%, STP - 150 ohms +/- 10%).

Table 3-1 Return Loss Characteristics

Return Loss	Frequency Range
> 16 dB	2 MHz - 30 MHz
> 16 dB - 20*log(f/30 MHz)	30 MHz - 60 MHz
> 10 dB	60 MHz - 100 MHz

3.5. Rise/Fall Times

The AOI signal rise is defined as a transition from logical ZERO to logical ONE. Signal fall is conversely defined as a transition from logical ONE to logical ZERO. The rise and fall times of the waveform is the time difference between the 10% and the 90% voltage levels of the signal transition excluding overshoot and undershoot of the waveform.

(R) Measured rise and fall times shall be between the limits:

$$1.5 \text{ ns} < \text{Trise/fall} < 3.5 \text{ ns.}$$

(R) The difference between the maximum and minimum of all measured rise and fall times shall be $< 0.5 \text{ ns}$.

3.6. Duty Cycle Distortion

Duty cycle distortion is measured at the 50% voltage crossing points on rise and fall transitions of the differential output waveform.

(R) The 50% voltage crossing times at three successive NRZ transitions for a 0101 bit sequence shall be used.

(R) The deviations of the 50% voltage crossing times from a best fit to a time grid of 6.43 ns spacing shall not exceed $\pm 0.25 \text{ ns}$.

(R) This measurement shall be made under the conditions that the baseline wander at the output of the AOI shall be less than 5% of the nominal value (V_{out}).

3.7. Jitter

The transmit jitter is determined by measuring the variation of the NRZ signal transitions at the 50% voltage crossings. For this measurement, the output of the transmitter is properly terminated in the reference load (Section 3.1). For all measurements in normal loop time applications, the network equipment transmit clock is used as the reference trigger.

(R) Total transmit jitter at the network equipment shall not exceed 1.5 ns peak to peak.

(R) Total transmit jitter at the user device shall not exceed 2.0 ns peak to peak.

3.8. Baseline Wander

Active output waveform droop is the decay of output voltage following a signal transition. Baseline wander tracking by a receiver is dependent on the worst case droop that can be produced by a transmitter. Worst case baseline wander bit sequences vary the transformer bias which causes the droop to change with data content. This variation must be accounted for by the receiver to track the baseline wander over long bit sequences.

(R) Output waveform droop shall be defined as the decrease in output voltage at the end of the sequence with respect to the differential transition voltage (neglecting overshoot) measured at the beginning of the transition.

(R) For the measurement of output waveform droop, the AOI shall be configured such that 100 bits of logical ONE are transmitted. The preceding bit pattern shall consist of an alternating sequence resulting in negligible ($< 1\%$) baseline wander.

(R) The output voltage droop shall not exceed 10% of the differential transition voltage amplitude.

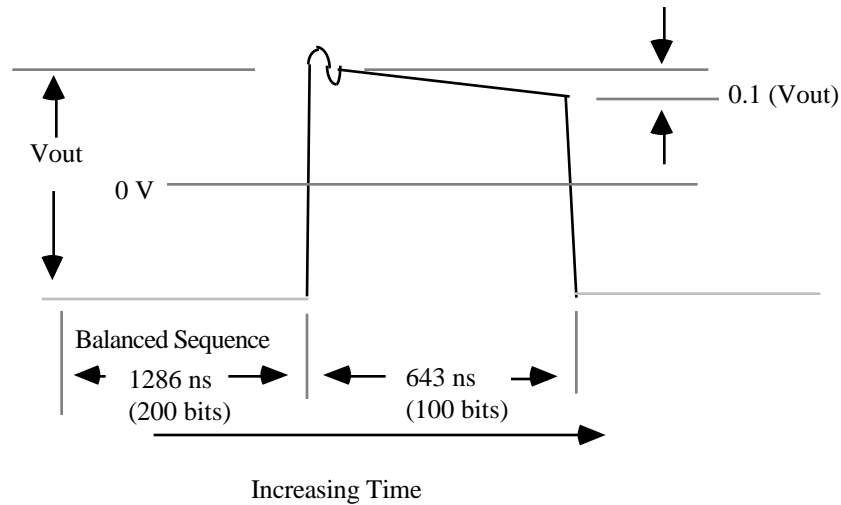

Figure 3-1 AOI Signal Droop

4. Active Input Interface (AII)

(R) The PMD sublayer shall provide a Receiver with functions in accordance with the electrical specifications of this Section.

(R) The Receiver shall transform the incoming differential voltage signal to an equivalent bit stream that is presented to the TC sublayer.

4.1. Differential Input Signals

The differential input signals RX+/RX- are defined at the output of the channel reference model with worst case electrical characteristics (described in Section 5) when the differential signals TX+/TX- at the input to the channel reference model are as specified in Section 3 (AOI).

(R) A positive voltage on the RX+ pin with respect to the RX- pin shall be decoded as a logical ONE. A positive voltage on the RX- pin with respect to the RX+ pin shall be decoded as a logical ZERO.

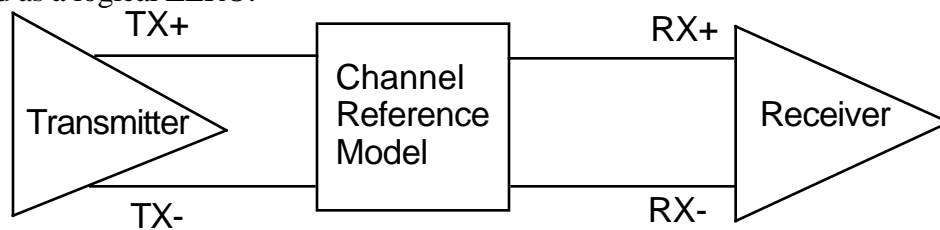

Figure 4-1 Differential Input Signals

4.2. Differential Return Loss

(R) The differential return loss from the differential receiver input signals RX+ and RX- shall be as listed in Table 4-1.

The requirement is specified for any reflection, due to differential signals incident upon RX+ and RX- from the media having any impedance within the range specified in Section 5.

(R) The return loss shall be measured when the receiver circuit is powered.

Table 4-1 Return Loss Characteristics

Return Loss	Frequency Range
> 16 dB	2 MHz - 30 MHz
$> (16 - 20 \cdot \log(f/30 \text{ MHz})) \text{ dB}$	30 - 60 MHz
> 10 dB	60 - 100 MHz

4.3. Common-Mode Rejection

(R) The Receiver PMD shall deliver the correct data signal to the TC interface with a less than 10^{-10} Bit Error Rate when Ecm is applied as shown in Figure 4-2. Ecm shall be a 1.0 V peak-to-peak sinusoid from 0 to 155 MHz.

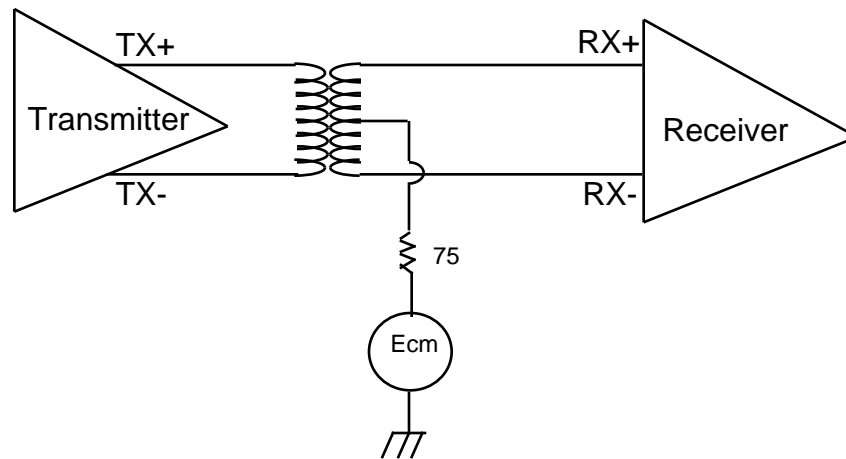

Figure 4-2 Common Mode Rejection

4.4. Input Jitter Tolerance

Specification of receiver jitter tolerance is not commonly done. This section is for informational purposes. Differential attenuation over the transmission band introduced by the cable severely distorts the signal. The amount of distortion differs with the length of cabling between the transmitter and receiver. Measuring jitter before the signal is equalized is meaningless. Furthermore, specifying a measurement point embedded within an implementation (i.e., at some point after the receive equalizer) is inappropriate since determination of compliance can not be achieved. Investigations have shown that the amount of jitter remaining in the recovered NRZ signal that can be attributed to the channel is approximately 1.5 ns,

although the sophistication of the equalizer can affect this number. Given the worst case AOI jitter as specified in Section 3, a receiver should be able to tolerate up to 3.5 ns of jitter in the NRZ data transitions. This leaves nearly 3.0 ns of worst-case eye-opening in the NRZ signal.

5. Copper Link Segment Characteristics

The copper link segment consists of one or more sections of twisted pair copper cable media containing two or four pairs along with intermediate connectors required to connect sections together and terminated at each end in the specified electrical data connector. The cable is interconnected to provide two continuous electrical paths which are connected to the interface port at each end. The AOI and AII requirements are specified for the media defined below. The implementation specified is for the horizontal distribution of the cable plant and extends from the telecommunications closet to the work area.

5.1. 100 Ohm Copper Link Segment

This section describes the link segment specifications, a channel reference model, and the Media Interface Connector (MIC) specifications for a 100 ohm link segment.

5.1.1. 100 Ohm UTP Link Segment Specifications Since the signals provided by the PMD contain significant high frequency energy, it is imperative to specify a high bandwidth channel which introduces negligible distortion in terms of both noise and dispersion. The electrical parameters important to link performance are attenuation, near end crosstalk loss (NEXT loss), characteristic impedance, and structural return loss (SRL).

(R) All components comprising a link segment shall meet or exceed all of the requirements for category 5 as specified by EIA/TIA-568-A^[1] and ISO/IEC DIS 11801^[2].

(R) The composite channel attenuation shall meet or exceed the category 5 attenuation performance limits defined in Annex E of EIA/TIA-568-A^[1].

(R) The composite channel NEXT loss shall meet or exceed the category 5 NEXT loss performance limits defined in Annex E of EIA/TIA-568-A^[1].

5.1.2. Channel Reference Model Configuration for 100 Ohm UTP Systems

The channel reference model for a category 5 UTP system is defined to be a link consisting of 90 meters of category 5 UTP cable, 10 meters of category 5 flexible cords, and four (4) category 5 connectors internal to the link.

5.1.3. Examples of 100 Ohm UTP Compliant Channels Since the link segment requirements for attenuation and NEXT loss are derived from the electrical performance of the channel reference model, the channel reference model (properly installed) defines a compliant link. Additionally, properly installed link segments consisting of no more than 90 meters of category 5 UTP cable, no more than 10 meters of category 5 flexible cords, and no more than 4 category 5 connectors internal to the link are examples of compliant links. However, any installed link consisting of category 5 components and meeting the link attenuation and NEXT requirements of Section 5.1.1. is compliant.

In many situations it is also possible to trade off attenuation for NEXT loss and derive links which may differ from the topology of the channel reference model but still have acceptable performance. The number of potential tradeoffs is quite large and this subject is beyond the scope of this document.

5.1.4. 100 Ohm UTP Attenuation Attenuation describes the loss in signal level as a signal propagates along a homogeneous medium such as a cable or cord.

(R) The category 5 cable used in constructing a link shall meet or exceed the horizontal UTP cable attenuation requirements of Chapter 10 of EIA/TIA-568-A^[1] and Chapter 7 of ISO/IEC DIS 11801^[2].

(R) The category 5 cordage used in constructing flexible cords and patch cables shall meet or exceed the attenuation requirements for flexible cordage specified in Chapter 10 of EIA/TIA-568-A^[1].

In general, the per unit length attenuation limits for cordage are 20% higher than those allowed for horizontal cables.

5.1.5. 100 Ohm UTP NEXT Loss NEXT loss defines the amount of unwanted signal coupling between distinct pairs of a multipair cable. It is the result of parasitic capacitive and inductive coupling between the various conductors comprising a cable.

(R) The category 5 cable and cordage used in constructing a link shall meet or exceed the horizontal UTP cable NEXT requirements of Chapter 10 of EIA/TIA-568-A^[1] and Chapter 7 of ISO/IEC DIS 11801^[2].

5.1.6. Characteristic Impedance and Structural Return Loss Characteristic impedance is the ratio of voltage to current of a wave propagating along one direction in a uniform transmission line. When a transmission line is not completely uniform in construction, the characteristic impedance may exhibit slight variations as a function of length. This variation is measured by a quantity defined as structural return loss (SRL). It is a measure of the deviation of characteristic impedance from a nominal value in a transmission line which is not perfectly homogeneous.

(R) All measurements for these quantities shall be done in accordance with ASTM D 4566 method 3^[4].

(R) Under these conditions both the characteristic impedance and SRL of category 5 cables and cords used in construction of a link shall meet the requirements specified in Chapter 10 of EIA/TIA-568-A^[1] and chapter 7 of ISO/IEC DIS 11801^[2].

5.1.7. 100 Ohm Connecting Hardware The electrical performance of connecting hardware can be critical to the overall performance of a transmission channel. In general, the electrical parameters specified for connecting hardware are attenuation, NEXT loss, and return loss. Inadvertent use of the wrong category of connecting hardware can seriously degrade performance including the emission characteristics for a category 5 link.

(R) All connecting hardware used within this PMD channel (outlets, transition connectors, patch panels, and cross-connect fields) shall meet or exceed the category 5 electrical

requirements for attenuation, NEXT loss, and return loss specified in Chapter 10 of EIA/TIA-568-A^[1] and Chapter 8 of ISO/IEC DIS 11801^[2].

(R) All measurements on connecting hardware shall be conducted in accordance with the procedures described in Annex B of EIA/TIA-568-A^[1] and Annex A.2 of ISO/IEC DIS 11801^[2]. These requirements apply to all individual UTP connectors, including patch panels, transition connectors, cross-connect fields, and telecommunications outlets.

The intent of this specification is to minimize the effects of UTP connecting hardware on end-to-end system performance. However, it should be noted that the requirements for connectors for category 5 UTP cable are not sufficient in themselves to insure system performance. Channel performance also depends upon cable characteristics, the care in which connectors are installed and maintained, and the total number of connections. Extreme care should be given to minimize the amount of untwisting involved with the installation of connectors as this is one of the prime sources of NEXT degradation.

(R) The connector termination practices and UTP cable practices described in Chapter 10 of EIA/TIA-568-A^[1] shall be followed.

5.1.8. UTP Media Interface Connector (UTP-MIC)(R) Each end of the category 5 UTP link segment shall be terminated with Media Interface Connectors specified in ISO/IEC 8877^[5]. (Commonly referred to as RJ-45.) This connector is an 8-pole modular jack/plug and mated combination shall meet the requirements of Section 5.1.7.

(R) The cable assembly shall connect the corresponding connects of the plugs at either end of the link. (i.e. Pin 1 to Pin 1, Pin 2 to Pin 2, etc.)

This ensures that the cable assembly is a straight through (no crossover) cable and that the polarity of the assembly is maintained.

(R) The UTP-MIC Receptacle (Jack) shall be an 8-pole connector that is attached to the ATM user device and ATM network equipment.

(R) The connect assignment for the UTP-MIC Receptacle (Jack) shall be as listed in Figure 5-1.

	Contact #	ATM User Device	ATM Network Equipment
 <p>(JACK)</p>	1	Transmit +	Receive +
	2	Transmit -	Receive -
	3	Note 1	Note 1
	4	Note 1	Note 1
	5	Note 1	Note 1
	6	Note 1	Note 1
	7	Receive +	Transmit +
	8	Receive -	Transmit -

Figure 5-1 UTP-MIC Receptacle (Jack) Contact Assignment Detail

Note 1: Refer to Part II Annex A for optional termination of these contacts.

5.2. 150 Ohm Link Segment Characteristics

The 150 ohm cable system connects the Active Interface on one end of the link segment to the Active Interface on the other end of the link segment. The cable system consists of one or more sections of shielded twisted pair cable containing two wire pairs, along with intermediate connectors required to connect sections together. The media interface connector is used to terminate the ends of the fixed wiring. The cable is interconnected to provide two continuous electrical paths between the Active Interfaces.

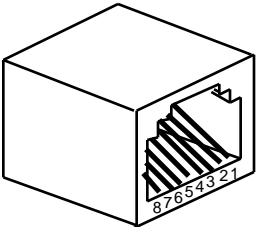
5.2.1. 150 Ohm STP Link Segment Specifications

The system can operate with a variety of STP cable types. EIA/TIA-568-A^[1] and ISO/IEC DIS 11801^[2] define STP cables which will meet the performance requirements of this system. The channel link requirements are independent of the cable type but have been defined using the attenuation and NEXT loss requirements for Category 5 UTP cable. The maximum allowable length of the cable system will vary depending on the quality of the STP cable, and patch cord.

(R) The composite channel attenuation for a 150 Ohm STP link shall meet the attenuation performance limits defined in Annex E of EIA/TIA-568-A^[1] for category 5 UTP cables.

(R) The composite channel NEXT loss for a 150 Ohm STP link shall meet the NEXT loss performance limits defined in Annex E of EIA/TIA-568-A^[1] for category 5 UTP cables.

(R) The characteristic impedance of the STP cable shall be 150 Ohm +/- 10%, from 3 - 100 MHz.

5.2.2. Channel Reference Model Configuration for 150 Ohm STP Systems

A typical cable system includes fixed cable terminated in the media interface connector, and attachment cables for both ends. The per unit length attenuation of an attachment cable is typically allowed to be up to 150% that of the fixed cable. Refer to ISO/IEC DIS 11801, Section 5 for more detailed information^[2].

The channel reference model for an STP system is defined to be a link consisting of 90 meters of STP-A cable, 10 meters of STP-A patch cord, and 4 STP-A connectors internal to the link.

5.2.3. Examples of 150 Ohm STP Compliant Channels

Since the link requirements for attenuation and NEXT loss are derived from the electrical performance of the channel reference model, the channel reference model (properly installed) defines a compliant link. A properly installed channel reference model defines a compliant link. Additionally, properly installed links consisting of no more than 90 meters STP-A cable, no more than 10 meters of STP-A patch cord, and no more than 4 STP-A connectors internal to the link are examples of compliant links. However, any installed link

consisting of STP components and meeting the link attenuation and NEXT requirements of Section 5.2.1 is compliant.

In many situations it is also possible to trade off attenuation for NEXT loss and derive links which may differ from the topology of the channel reference model but still have acceptable performance. The number of potential tradeoffs is quite large and this subject is beyond the scope of this document.

5.2.4. STP Media Interface Connector

(R) Each end of the fixed cable shall be terminated in the STP media interface connector.

(R) The STP media interface connector shall meet all the requirements of the Telecommunications Connector as defined in EIA/TIA-568-A, Section 11^[1].

(R) The STP media interface connector contact assignments shall be as listed in Table 5-1.

Table 5-1 STP MIC Contact Assignments

MIC Contact	ATM User Device	ATM Network Equipment
B	Transmit +	Receive +
R	Receive +	Transmit +
G	Receive -	Transmit -
O	Transmit -	Receive -

The STP MIC drawing is included for reference in Figure 5-2.

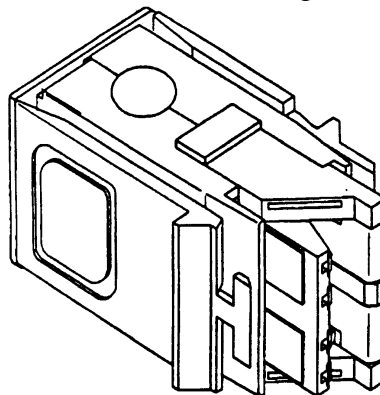

Figure 5-2 STP Media Interface Connector

5.2.5. STP Active Interface Connector

To allow maximum flexibility in system design, and allow for future connector enhancements, an optional Active Interface Connector is specified.

The patch cord between the wall connector and the terminal device provides interconnection capability between any connector and the STP Media Interface Connector. The use of an alternative STP connector is optional. It allows STP system designers to use a common connector where appropriate.

5.2.5.1. Optional STP Active Interface Connector

The optional connector may be used at one end or both ends of a link segment.

(CR) The optional STP Active Interface Connector shall be a 9-pole D-Shell connector that meets the requirements in EIA/TIA 574:1990 Section 2 as it relates to intermateability[7].

(CR) When the optional 9-pole D-Shell connector is used, the Receptacle (Jack) shall be mounted on the equipment (ATM Network Equipment and ATM User Equipment) and the Plug connector shall be used on the STP cable.

(CR) The 9-pole D-Shell Receptacle shall be used with contact assignments as listed in Figure 5-3.

9-Pole D Connector (Jack)	Contact #	ATM Network Equipment Signal	ATM User Equipment Signal
	1	Transmit +	Receive +
	2	Not used	Not used
	3	Not used	Not used
	4	Not used	Not used
	5	Receive +	Transmit +
	6	Transmit -	Receive -
	7	Not used	Not used
	8	Not used	Not used
	9	Receive -	Transmit -
	Shell	Chassis	Chassis

Figure 5-3 STP 9-Pole D Connector Contact Assignment

5.3. Noise Environment
5.3.1. Self NEXT Channel Noise
 In order for a channel to support data traffic at the desired BER performance level, the crosstalk noise from all sources must be limited to an acceptable level.

(R) The time domain crosstalk noise from all data signals in the channel shall be no more than 20 mV peak-to-peak.

The noise environment consists of primarily two contributors; NEXT noise from all data signals in the cable (including self NEXT noise) and externally induced impulse noise from other office and building equipment. Impulse noise is generally the result of mechanical switching transients and common mode coupling phenomena.

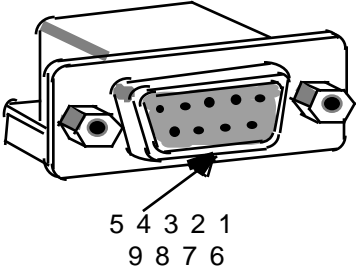
3.2. Electromagnetic Susceptibility and Impulse (Fast Transient)

Noise Refer to Annex B for guidelines on electromagnetic susceptibility and impulse noise guidelines.

6. References

[1] EIA/TIA Standards Proposal No. 2840-A, EIA/TIA-568-A, "Commercial Building & Wiring Telecommunications Wiring Standard," Draft Ballot, March 29, 1994.

- [2] ISO/IEC DIS 11801, JTC1/SC25 N106, "Generic Cabling for Customer Premises," Draft Ballot, October 12, 1992.
- [3] The ATM Forum Technical Committee, ATM User Network Interface Specification, Version 3.1, Prentice Hall, Englewood Cliffs, NJ, 1994.
- [4] ASTM Designation: D 4566-90, "Standard Test Methods for Electrical Performance Properties of Insulations and Jackets for Telecommunications Wire and Cable," 1990.
- [5] ISO 8877, "Informational processing systems, Interface connector and contact assignments for ISDN basic access interface located at reference points S and T.," August 15, 1987.
- [6] 88025 / ISO Rev. 2, "Token Ring Access Method and Physical Layer Specifications," Letter Ballot 1994.
- [7] ANSI EIA/TIA 574, "9 Position Non-Synchronous Interface between DTE and DCTE employing Serial Binary Data Interchange," 1990.
- [8] Solid State Radio Engineering, H. Kraus, C. Bostran, F. Raab, ISBN 0-471-03018-X, John Wiley & Sons, Inc., 1980.
- [9] Antenna Impedance Matching, W. Caron, ISBN 0-87259-220-0, The ARRL, 1989.
- [10] IEC 801-3, International Electrotechnical Commission, IEC Standard, "Electromagnetic Compatibility for Industrial-Process Measurement and Control Equipment, Part 3: Radiated Electromagnetic Field Requirements," 1992.
- [11] IEC 801-4, International Electrotechnical Commission, IEC Standard, "Electromagnetic Compatibility for Industrial-Process Measurement and Control Equipment, Part 4: Electrical Fast Transient/Burst Requirements," 1991.

Annex A (Informative) System Balance (Common Mode Rejection)

ConsiderationsThe system or link interface balance (e.g., transmitter and cable plant) does not directly constrain the interoperability of SONET/SDH UTP conforming UNIs, but poor balance will cause the differential line signal to be partially converted to common mode (also called longitudinal mode) on the cable plant. The resulting common mode currents will likely result in electromagnetic emissions which may potentially violate statutory emission or susceptibility requirements. While a detailed treatment of this subject is beyond the scope of this specification, a more thorough understanding of the system considerations may be found in EIA/TIA-568-A^[1] and ISO/IEC DIS 11801^[2].

As this behavior is a system effect, it is desirable that equipment implementations not be the dominant contributor to conversion. As a guideline to implementors, data have shown that a typical category 5 cable plant exhibits common mode rejection of approximately 40 dB. The Annex sections below details recommendations which may be useful during system design and test to aid the implementor in meeting the particular EMC requirements.

A.1. Common Mode Signal Rejection Guidelines at the UTP MIC

Common Mode Signals present on the UTP medium connected to the MIC due to an imbalance in the transmitted differential data signal or electrically noisy ground references may cause radiated radio frequency emissions in excess of regulatory agency requirements. Unlike lower speed protocols with clocks and baud rates below the 30 MHz radiated emission frequency limit, the SONET NRZ data signal consists of spectral components in excess of 75 MHz with a clock frequency of 155 MHz.

It has been demonstrated that operation with emissions below the FCC and CISPR Class B limits are practical due to the superior balance of the category 5 cable when driven by balanced signals with each line referenced to an electrically quiet ground reference. This may be achieved if RF techniques are used in the design of the interface.

It should be understood that the cable connected to the MIC forms a random length monopole antenna. The efficiency of this antenna is a function of the physical configuration of the cable, and more importantly, the efficiency of the coupling of any common mode signals to the common mode impedance of the cable. The common mode signal may be generated by an imbalance in the differential data driver or by inadvertent coupling of clocks or other signals on the PC board to the MIC. The common mode impedance of the cable, and generally the MIC are complex and the typical method of common mode characterization in a 50 Ohm measurement system is inadequate to predict radiated emission performance of either in an open field test environment. The metric which would ensure emission compliance is a measurement of the true amount of common mode power available at the MIC into any common mode impedance presented to the port by a connected cable.

If one makes a reasonable estimate of the realizable gain of the cable when driven as a monopole due to directional effects, one can determine the maximum common mode power level allowed at the MIC. The requirement at test is that the common mode impedance of the port be matched to the measurement device at the frequency of the measurement. This will be the complex conjugate of the common mode output impedance of the port under test with real impedance matched to the input impedance of the measurement device.

A practical implementation of this measurement technique may consist of simultaneously terminating each of the 4 pair connections at the MIC into a combination center tapped auto-transformer and 100 Ohm termination resistor, with the center taps of the transformers joined and measurements made of this point with respect to a front panel ground reference of the device under test. At frequencies where signal levels seem suspect, the common mode impedance of the point should be measured, and a conjugate match designed to couple the power to the measurement device. Output impedance may be measured using an S-parameter test set, and methods to effect the matching network are available in literature referring to radio frequency engineering design techniques.^[8,9] RF design techniques must be employed when designing this test fixture.

A more straightforward measurement technique is the measurement of current maxima which occur on the cable when driven by a port using an inductively coupled current clamp. Though not as exact as the above method of measurement, correlation to the open field test site should be adequate.

To employ this technique, the current level at a suspect frequency should be isolated using the current clamp. At this frequency, the physical location of the current clamp should be moved over a distance of at least an electrical half-wavelength to determine a current maximum. This test should be performed as close to the port as possible. The level of current observed should be compared to the current required at the center of an equivalent half-wave dipole that will radiate a field in excess of that allowed. In effect, the cable itself becomes the conjugate match of the port. A requirement is that the linear dimension of the cable should be longer than a halfwave length at the frequency of measurement. Calibrated current clamps are common in the industry.

Derivations of typical limits of port measurements as discussed are presented in the following sections..

A.1.1. Common Mode Power

If one assumes a maximum "Antenna Gain" of 6 dB over an isotropic radiator for the cable¹ and an emission limit of 30 dB μ V, the maximum common mode power allowed at the port is:

$$P_{\text{port}} = \{r * E_0\}^2 / (30 * G_t)$$

Where:

P_{port} = Power at port

r = Radius from transmitter to receiving antenna in meters

E_0 = Field strength in V/m

G_t = Antenna gain above an isotropic radiator

$$\begin{aligned} P_{\text{port}} &= \{10 \text{ m} * 31.62 * 10^{-6} \text{ V/m}\}^2 / (30 * 4) \\ &= 833 * 10^{-12} \text{ Watts} \\ &= -61 \text{ dBm} \end{aligned}$$

¹ This value is a conservative estimate since antenna gain is difficult to calculate using simple wire configurations.

The frequency versus radiated field limits are dependent upon local agency requirements and this analysis should be modified accordingly.

A.1.2. Common Mode Current

In order to determine the maximum common mode current allowed on the cable, one calculates the current at the center of a half wave dipole which is radiating a field strength of 30 dB μ V at 10 meters.

The power gain of a half wave dipole is 1.64 times that of an isotropic source. The power applied to this dipole is :

$$P = \{10 \text{ m} * 31.62 * 10^{-6} \text{ V/m}\}^2 / (30 * 1.64) = 2 * 10^{-9} \text{ Watts}$$

The radiation resistance of a half wave dipole is 73 Ohms,

$$I = \text{SQRT}(P/R) = \text{SQRT}(2 * 10^{-9} \text{ Watts} / 73 \text{ Ohms})$$

$$= 5.2 \mu\text{A}$$

when observed in a 100 kHz Bandwidth. The 6 dB "antenna gain" is not included in this calculation since it is a direct result of multiple current maxima occurring at half wave intervals on a long cable, and we are measuring the current at only one point on the cable at a time.

A.1.3. Common Mode Rejection

In order to determine the "Common Mode Rejection" required of the transmitter, one must first determine what portion of the transmitted data signal power is present in the 100 kHz measurement bandwidth specified by the Class B limits. The ratio of this power to the -61 dBm of common mode power we are allowed at the port is the common mode rejection required.

The power spectrum of the data signal takes the form of $(\sin X / X)^2$ with nulls occurring at multiples of the bit-rate. Since radiated measurements are performed only above 30 MHz, the maximum density of common mode power available to radiate will occur in a passband from 30 to 30 MHz. Evaluating the integral of the power available at this point relative to the total power transmitted in an infinite passband gives us a ratio of 29.2 dB. If we assume rectangular pulse shaping at the transmitter, and a 1V peak to peak drive level, the transmitted power is $(0.5)^2 / 100 = 2.5 \text{ mW}$ or +4 dBm.

$$\text{Common Mode Rejection (dB)} = P_{\text{trans}} - P_{\text{port}} - D_{\text{gain}}$$

Where: P_{trans} = Transmitted Power (dBm)
 P_{port} = Common Mode Power at port (dBm)
 D_{gain} = Dispersion Gain due to scrambling

$$4 \text{ dBm} - (-61 \text{ dBm}) - 29.2 \text{ dB} = 35.8 \text{ dB}$$

Actual common mode rejection required at other frequencies may be determined by evaluating the $(\sin X / X)^2$ power spectrum in a 100 kHz bandwidth at that frequency. The common mode rejection specification alone will not ensure compliance if other sources of common mode energy are coupled to the port.

A.1.4. Common Mode Measurement Conclusions

These measurement techniques are suggested as a guide to those interested the quantitative measurement of the emission performance at the MIC in a laboratory environment prior to open field test site measurements of the product. It will also aid the designer in specifying components used in the MIC cable driver when specifying their common mode characteristics. The accuracy of the results is totally dependent upon the care with which these measurements are performed.

A.2. Common Mode Termination Guidelines

This section outlines methods of terminating the twisted pair cable for improved EMC performance. Such improvements include reduction of radiated emissions and increased immunity to electromagnetic noise. Techniques as outlined below may prove beneficial in some implementations.

Work shown has indicated that such techniques have no impact on interoperability between PMD implementations. That is to say, the presence or absence of such a technique on a ATM system on one side of a UNI does not affect the ability of the alternate UNI station to interoperate across the link segment.

As an example, three techniques of terminating the unused pairs of the cable are outlined below. The first consists of a scheme in which the common mode impedance of the cable pairs is resistively terminated at the UNI. Such a scheme could be implemented as shown in Figure A-1. The second technique involves the termination of one or more of the unused cable pairs to the chassis reference of the equipment. Such a scheme could be implemented as shown in Figure A-2. The third technique is a derivation of the second and includes longitudinal chokes in the active pairs. Such a scheme could be implemented as shown in Figure A-3. It should be noted that these techniques as described here may have patent or patent pending implications. The ATM Forum patent policy has been followed with respect to any known patent related issues at the time of specification approval.

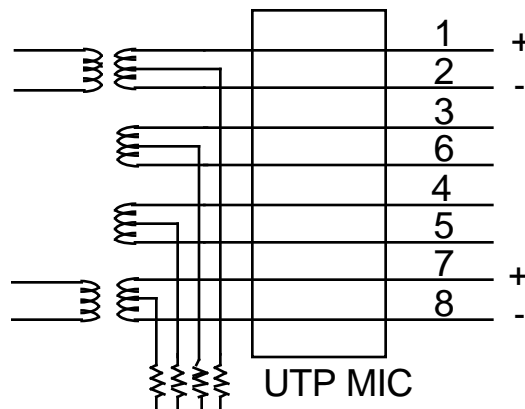

Figure A-1 Example of Common Mode Resistive Termination of Pairs

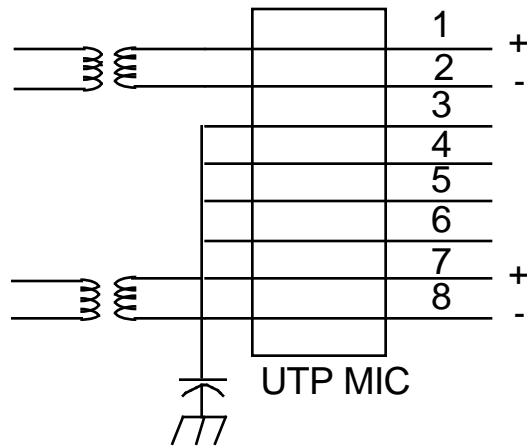

Figure A-2 Example of Common Mode Termination to Chassis Reference

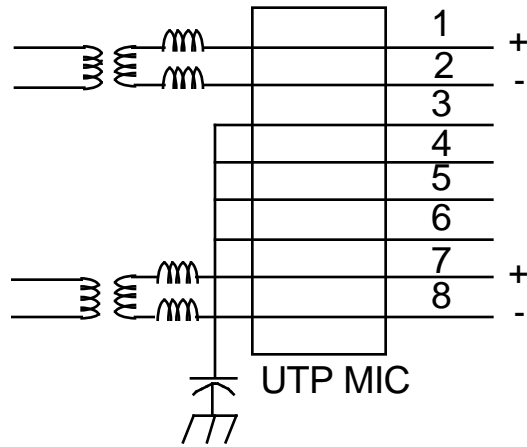

Figure A-3 Example of Common Mode Termination to Chassis Reference with Chokes

Annex B. (Informative) Electromagnetic Susceptibility and Impulse Noise Guidelines

B.1. Electromagnetic Susceptibility

With no degradation in BER, the PMD/PHY implementation should pass a 3 V/m field electromagnetic susceptibility test (IEC 801-3, Level 2). The PMD/PHY should be tested using the test methods described in IEC 801-3^[10].

B.2. Impulse (Fast Transient) Noise Since the majority of impulse noise is generated by mechanical switching, the requirements for impulse noise should be generated by standard tests designed to simulate this phenomena.

The PMD/PHY implementation operating on media cables, should recover without operator intervention, from 0.5 kV impulse noises (fast transients) (IEC 801-4, Level 2). The PMD/PHY should be tested using the test methods described in IEC 801-4^[11].